

## Recommended Soldering Techniques

### Introduction

The soldering process is the means by which electronic components are mechanically and electrically connected into the circuit assembly. Adhering to good soldering practices will preserve the inherent reliability of the original components and ensure a good, reliable connection of the component into the circuit assembly.

### Soldering Considerations

**Substrates :** A substrate is a material which constitutes a *printed circuit board*, commonly called a PCB.

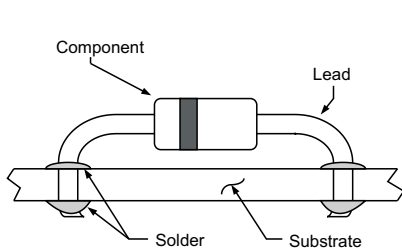

Fig. 1. Axial-Leaded Components

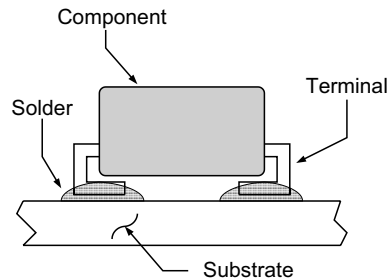

Fig. 2. Surface Mount Components

There are many different types of PCB substrate materials. Among the most common are the following:

<b>Substrate</b>	<b>Advantages</b>	<b>Disadvantages</b>
Phenolic	Very inexpensive, easy to punch and drill.	Poor resistance to vibration and mechanical shock.
FR-4	Inexpensive, moderately easy to drill.	Cannot be punched, heavy components need mechanical support.
Alumina	Good resistance to mechanical shock.	Expensive, poor coefficient of expansion match to glass.

To select the most appropriate substrate material for the application, the designer of the circuit assembly must weigh these five factors:

1. coefficients of expansion for all the components which will be soldered onto the PCB,
2. coefficient of expansion for the substrate,
3. cost of the substrate,
4. cost of any secondary operations to the substrate, such as the drilling of “*through-holes*”, and
5. application-specific issues, such as vibration resistance and weight.

It is important to match the coefficients of expansion for the components to those for the PC board. When a PCB assembly is soldered and the coefficients of expansion for the components and the PC board are not matched, the solder joints may crack or the bodies of the parts may crack or shatter as the assembly cools.

**PCB Pad Layout and Solder Paste Thickness:** It is important to use proper layout patterns in order to ensure good solder connections, especially for surface mount components soldered by a reflow process. Many surface mount components have more than three terminals which form the “footprint” for the devices. Ideally, every terminal of the device would be formed to create a perfect mounting plane. In the real world, there is a tolerance associated with how close each lead comes to meeting the intended plane. A measure of this characteristic is called *coplanarity*. In most cases, some of the terminals of a device will not be perfectly aligned with the intended mounting plane. In an infrared reflow solder process, the PCB pads are coated with a solder paste (Figure 3). When the assembly is heated in an oven, the solder paste warms and reflows. As the solder paste liquefies, it forms an apex at the center of the PCB pad. This apex must contact the terminal of the device in order to make contact. When using an IR reflow process, the solder process engineer must take into account the pad layout and the coplanarity of the devices when determining the solder paste thickness. Figure 4 shows a failure mode where the device has poor coplanarity and the solder paste thickness is insufficient for the apex of the liquefied solder to contact the poorly formed terminal.

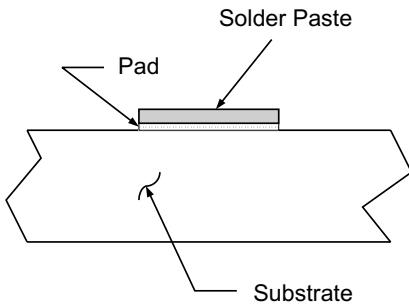

Fig. 3. PCB With Solder Paste Before Component Insertion and Reflow

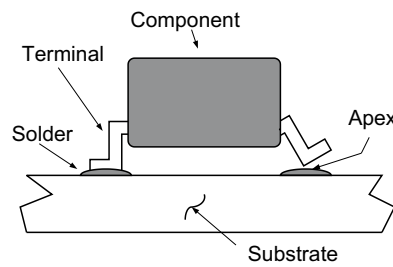

Fig. 4. Device Exhibiting Poor Coplanarity

Care must also be taken not to use too much solder paste. Excessive solder paste will result in too much solder on the pad. The terminals of many surface mount components are designed to flex, which allows the terminals of the component to withstand mechanical and thermal stress without fracturing. When excessive solder is applied, the terminals become captivated within the solder and force is transferred away from the terminals and into the internal structure of the device. This can lead to immediate or latent failures. Figure 5 shows a solder connection with the proper amount of solder and figure 6 shows excessive solder.

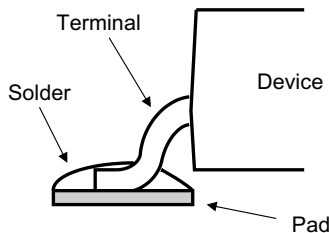

Fig. 5. A Good Solder Connection

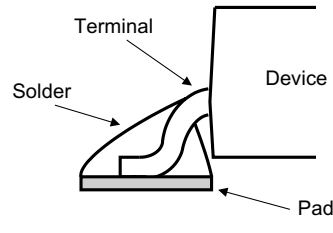

Fig. 6. Excessive Solder

**Fluxing and Cleaning:** Another major consideration in soldering is fluxing. *Flux*, used in conjunction with solder during the soldering process, is the material that aids the solder in flowing. The selection of the proper flux and its correct application are essential to proper soldering. Fluxes have differing levels of *activity*, or abilities to remove contaminants from the device terminals and PCB pads.

A key characteristic of fluxes is their *solubility*. The solubility of the flux determines which wash processes can be used to remove the flux. In the past, many circuit assembly facilities used active, non-water soluble fluxes. Active fluxes are able to remove surface oxides from the leads or terminals of the devices and result in even, smooth solder joints with excellent wettability. However, active fluxes are highly corrosive. When active fluxes are not completely removed, the solder joints are more likely to corrode and the long-term reliability of the assembly may be degraded. Active fluxes must be removed from the PCB. The removal process is called *cleaning* or *washing*. Many materials which are highly effective at removing flux (such as *freon* and *trichloroethane*) became subject to environmental legislation several years ago, and they are now illegal in environmentally-conscious countries. As a result of these concerns, the following two trends have emerged:

1. Some circuit assemblers have migrated to *low activity fluxes*. Fluxes are available now which have such low activity levels that it is not necessary to remove them from the PCB. Such fluxes are commonly referred to as “no-wash” “leave-on” fluxes. However, low activity fluxes frequently lead to wettability problems. *Wettability* is a measure of how well the solder joins the device lead or terminal to the PC board (Figure 7). Two important factors in a low-activity flux process are the cleanliness of the device leads or terminals, and the plating thickness of the leads or terminals. If the terminals of a device are not sufficiently clean, *de-wetting* can occur. If the plating thickness of the device terminals is insufficient, *non-wetting* can occur.

- *De-wetting:* Fluxes with low activity levels are not as effective at removing oxides and contaminants from device leads or terminals as active fluxes. When contaminants are not properly removed from the pads and/or the leads of the devices, *de-wetting* can occur. De-wetting is characterized by irregular and dispersed solder droplets on the joint surface, often separated by a thin layer of solder between them.
- *Non-wetting:* Solder may not adhere to the leads or terminals of a device if the plating thickness is too thin. This problem especially applies to axial-leaded devices since the solder must bridge across the through-hole from the pad to the lead (Figure 8).

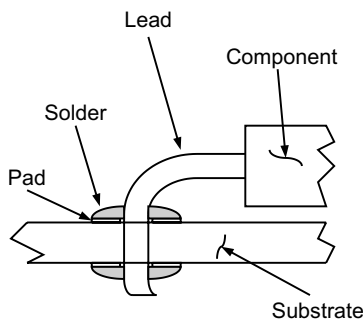

Fig. 7. A Solder Joint Exhibiting Good Wetting

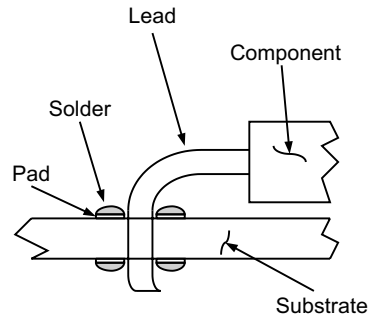

Fig. 8. Non-wetting Solder Joint

2. Due to the aforementioned concerns pertaining to low activity fluxes, the electronics industry has developed highly active fluxes which are water soluble. These new types of fluxes offer the effectiveness of a highly active flux in conjunction with water-solubility for ease of cleaning.

**Plating Composition:** The leads or terminals of components usually consist of either copper, a copper *alloy*, or other alloys such as *dumet*. The leads are plated with one or more other metals. Three common plating materials are tin, lead, and silver. The composition of the plating material directly affects the solderability of the device. When an alloy is used for plating, the temperature at which it transitions from its solid to liquid state is called the *eutectic* temperature. Many axial-leaded components are plated with either 100% Tin (Sn), or 90% Tin (Sn)/10% Lead (Pb). 100% Tin has a melting point of approximately 232°C, and 90Sn/10Pb has a eutectic temperature of approximately 216°C. Many surface mount components are plated with an alloy of 60% Tin, 40% Lead (Pb), which is eutectic at approximately 190°C. The eutectic temperature of the plating alloy determines the minimum limit of the soldering process temperature in order to reflow the plating on the device's leads or terminals.

**Body Composition:** The body composition of the devices is also pertinent to the soldering process. The body material of many components consists of plastic epoxies, which can be grouped into two main categories:

- *Thermoplastics:* Thermoplastics can be melted and remolded more than once. One such body material is called *Thermoplast*, which melts at around 280°C. Thermoplast has a melting temperature which is relatively close to the eutectic point of the plating on their leads or terminals. Solder process engineers should make sure that the peak soldering temperature does not exceed the melting temperature of any thermoplastic-bodied devices.
- *Thermosetting plastics:* In contrast to thermoplastics, thermosetting plastics, such as Duroplast, are formed only once. Subsequent exposures to high temperatures (such as those in the range of most solder processes) cause the material to harden instead of soften. Exposure to excessively high heat causes a thermosetting plastic to crack or crumble.

## Soldering Methods and Process Stages

Soldering methods commonly used today include:

- *Wave soldering:* Wave soldering is still widely employed for axial leaded devices and for mixed technology boards. Surface mount components can be wave soldered successfully if the recommendations in this document are followed. Surface mount components must first be mounted to the PCB with an adhesive before they can pass through the solder wave.
- *Reflow soldering:* Most surface mount components are reflow soldered. The two major types of reflow processes are:
  1. *infrared reflow* - the most common type of reflow process.
  2. *vapor phase reflow* - rapidly disappearing due to environmental restrictions on fluorocarbons.

There are four process stages in soldering:

1. *Preheat:* The preheat process is very important in any kind of soldering process. To avoid thermally shocking the components, PCB assemblies must be preheated. Immediate or latent damage can occur to the components if they are not preheated properly.
2. *Soak:* A soak period is advisable so that components of differing thermal mass will approach a similar temperature prior to the peak stage. During reflow soldering, this is the period where the flux begins to break down the oxides which would inhibit solder adhesion.

## Soldering Methods and Process Stages (continued)

### 3. Peak/Reflow:

- **Temperature:** The range of the peak soldering temperature depends on several factors, two of which have been described in previous sections: plating and body compositions. The minimum soldering temperature range should be at least 5-10°C higher than the eutectic temperature of the plating alloy. The maximum soldering temperature should be at least 5-10°C lower than the melting temperature of any thermoplastic components (if used).
  - **Time:** The devices must be held at the peak soldering temperature long enough to ensure the proper wetting of the solder connections. However, keeping the peak soldering time to a minimum to avoid the possibility of damage to the devices and to increase throughput, is recommended.
4. **Cool down:** After the devices are exposed to the peak soldering temperature, they go through a cool down process. Although some manufacturers cool their PCB assemblies in free air, it is better to use a controlled temperature chamber for superior control of the thermal gradient.

## Suggested Thermal Profiles for Soldering Processes

Diodes Incorporated presents the following general thermal profiles for soldering processes (Figures 9 and 10) as examples only. The solder process engineer should always optimize the thermal profile for each circuit assembly based on its specific requirements.

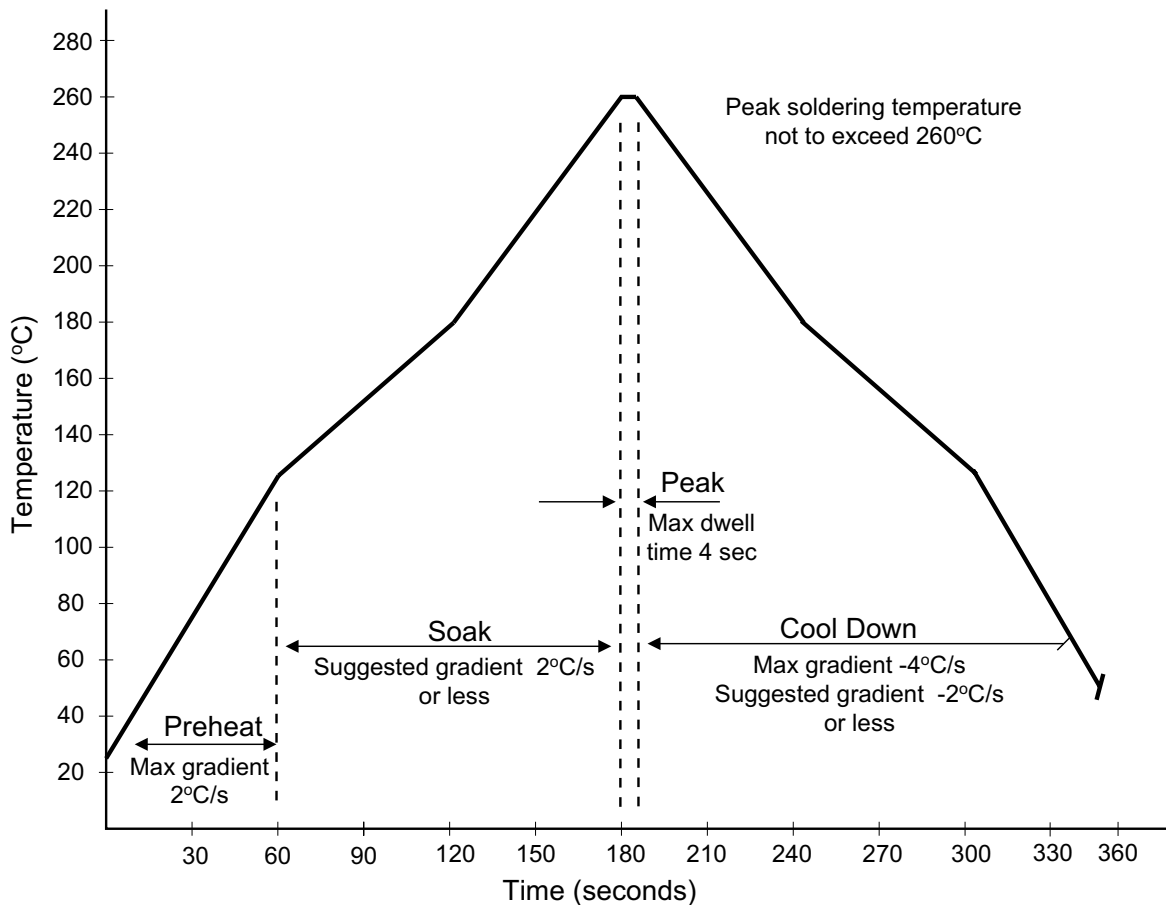

Fig. 9. Typical Wave Soldering Thermal Profile

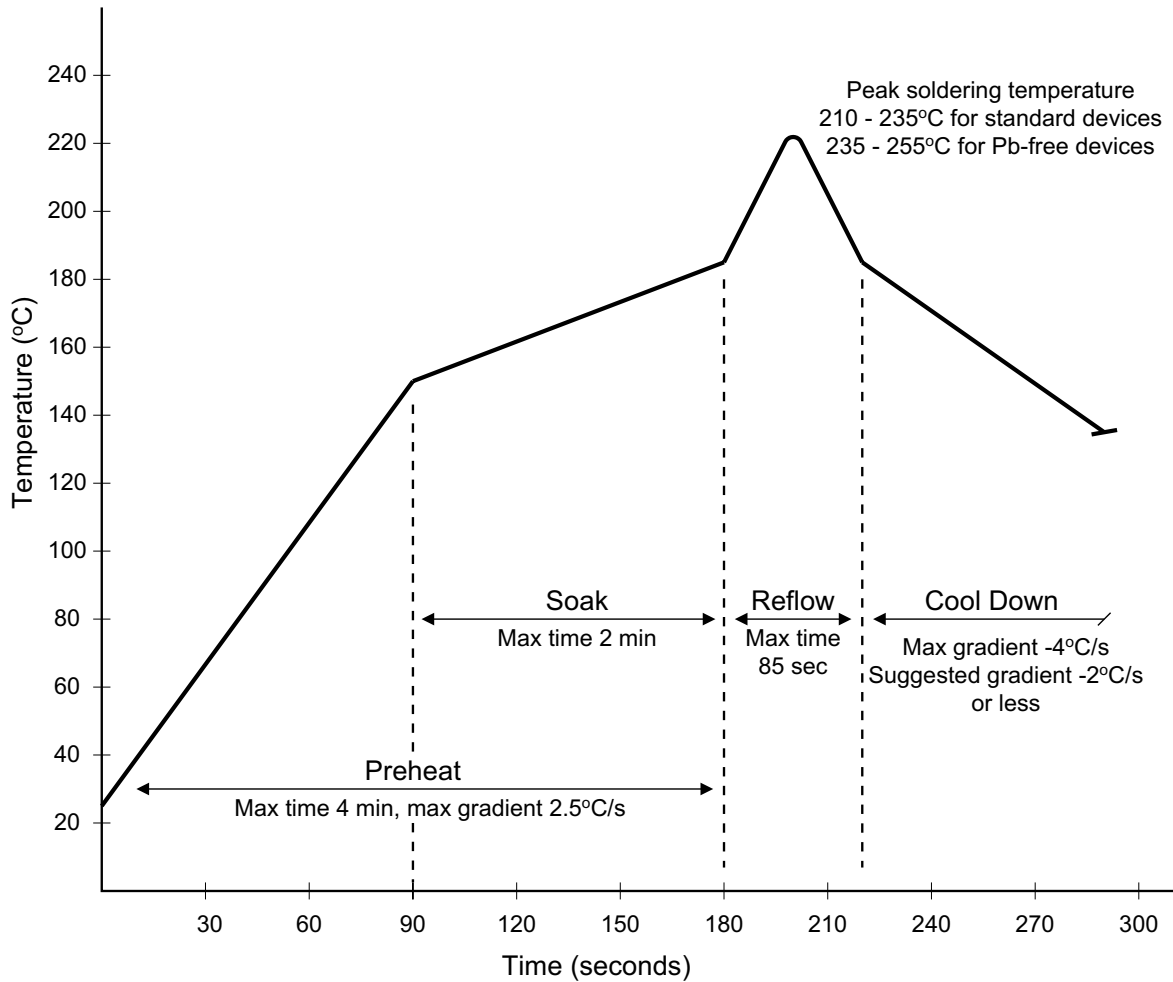

Fig. 10. Typical IR Reflow Soldering Thermal Profile

## Soldering Process Suggestions

1. One of the first surface mount packages that was introduced to and accepted by the manufacturing community was the plastic MELF (metalized electrode face) package. Although plastic MELF products are often used in wave solder applications, their long-term reliability may be adversely affected if they are used in a non-optimized wave solder process. Superior surface mount packages have been developed since their introduction that have proven to be more rugged and more reliable in wave solder processes. In particular, we recommend our SMA, SMB, SMC, PowerDI™123 and PowerDI™5 style devices. Please review our suggested pad layout document (<http://www.diodes.com/datasheets/ap02001.pdf>) for converting PCB layouts from MELF to SMA, SMB or PowerDI™5.
2. Due to the differing thermal capacities of large and small components and equipment wear, localized “hot spots” and “cold spots” may be generated during reflow soldering. Special care should be taken to avoid the damage of small components in “hot spots” and de-wetting or non-wetting of larger components in “cold spots”. A good practice is to mount miniature thermocouples in several locations on the PCB which are suspected to be hot and cold spots. The reflow solder profile can then be adjusted accordingly to result in optimal soldering. A good practice is to place the PCB assemblies at regular, repeated positions on the conveyor system to achieve uniform soldering on successive assemblies.

## Soldering Process Suggestions (Continued)

3. The leads on most Diodes Inc. RoHS compliant (Pb-free) devices have a Matte Tin (Sn) plating finish over an ALLOY 42 Lead Frame. Some devices have silver (Ag) plating. The Matte Tin finish requires a higher solder temperature (235-255°C) than our standard products (217-235°C), which have an tin/lead (Sn-Pb) finish.
4. IPC/JEDEC document J-STD-020C provides a reflow profile applicable to both Sn-Pb and Pb-free devices. This profile is not a recommendation for reflow soldering. Rather, it is a temperature vs. time profile that a device must withstand without failure in order to maintain a desired moisture sensitivity level. In that sense, it represents the maximum stress to which a device should be subjected.
5. Diodes Inc. soldering recommendations are within the JEDEC profile and should be considered a reasonable starting point in developing a profile for reflow soldering. Actual temperatures will depend on your soldering alloy, PCB layout, weight of copper, pad sizes, and other variables. In any event, temperatures in excess of 260°C violate Diodes Inc. specifications.

## Recommendations for Rework

**Hot Gas Pencils:** Hot gas pencils should be set up to limit the gas temperature to a maximum of 300°C at a distance of 3mm from the nozzle tip.

### Soldering Irons:

1. Only thermostatically-controlled irons should be used. The bit should have a diameter not exceeding 1mm and should be set so that its maximum temperature never exceeds 300°C.
2. The bit must not touch the component body. Contact should only be with the component leads or the land pads on the printed circuit board (Figure 11).
3. The maximum permitted temperature-time combination on the component lead is 300°C for 10 seconds.

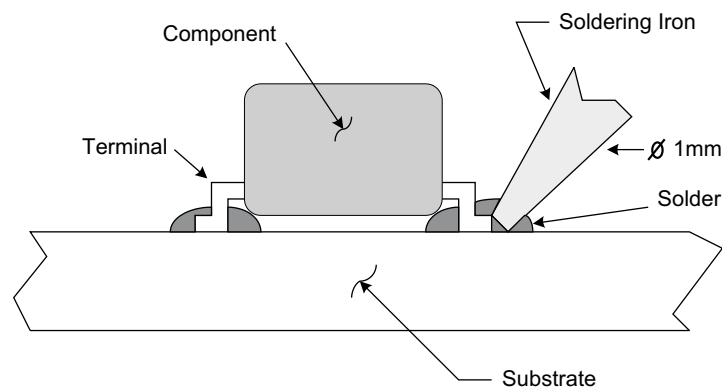

Fig. 11. Rework by Soldering Iron